

THE HOUSE OF ARTS & CULTURE

The Lebanese – Omani Centre

Our first objective for the Lebanon House of Arts and Culture was for it to be a positive addition to the city and its surroundings. We used the few existing green areas to create a public boulevard that crosses the building form north to South. The central axis organizes the required programme of the building, some of which will be open 24 hours a day for the community. The green areas of the building are flexible so that they can be used as public or private spaces; as well as in different hours of the day depending on its use.

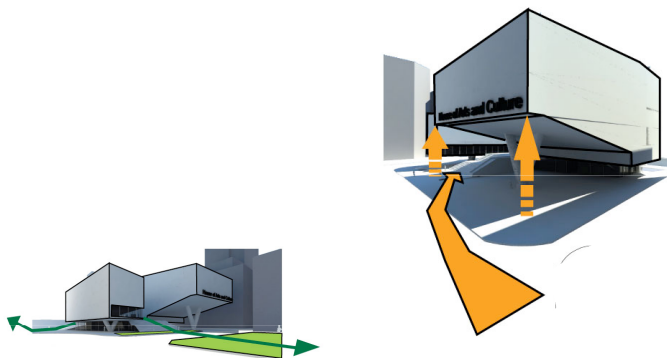
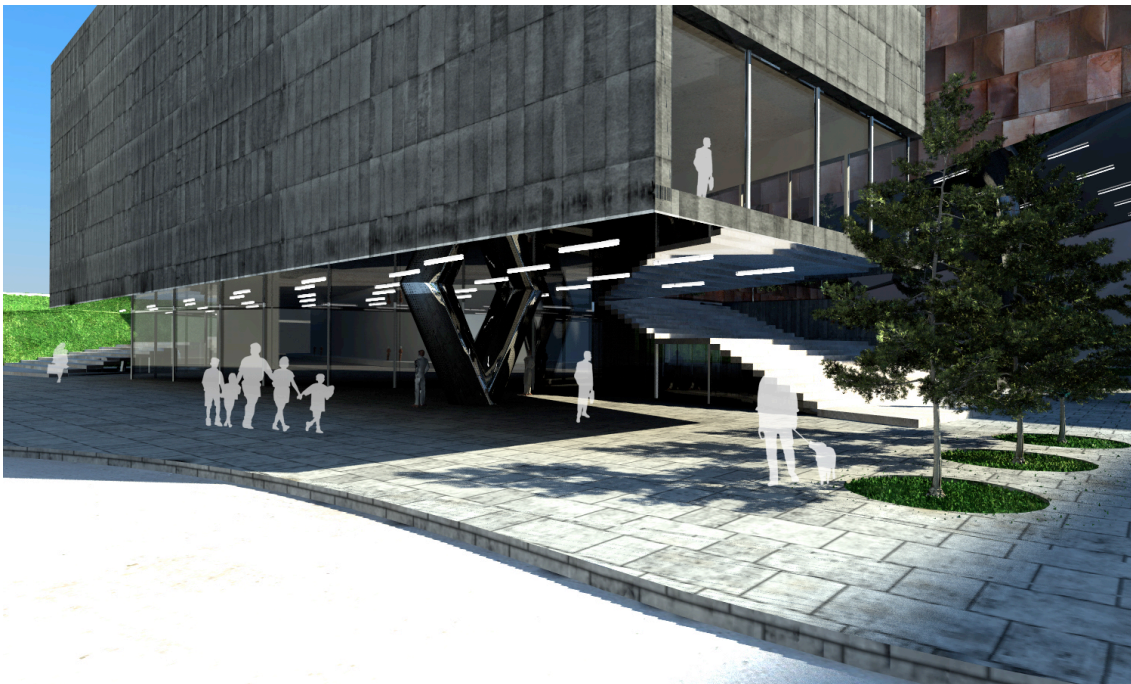

The architectural programme was designed on the 2nd floor, leaving the ground floor for the access hall and the 3 public plazas. The 3 buildings offer 3 different programmes. Under each of these buildings are public plazas that are reflected on the ceiling to expose the civil activities of the city.

